

True RMS Digital MultiMeter Series

Models DM62, DM64, and DM66

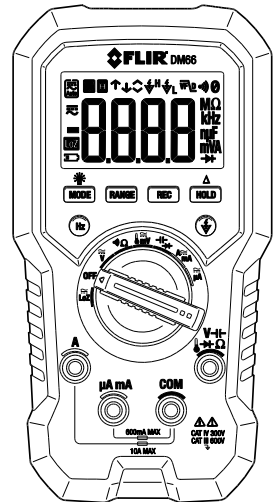
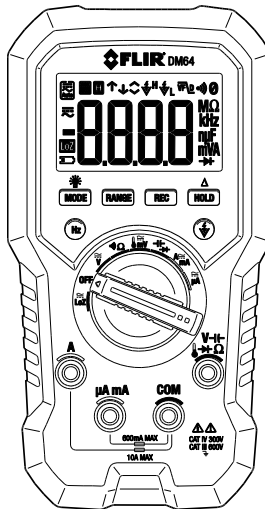
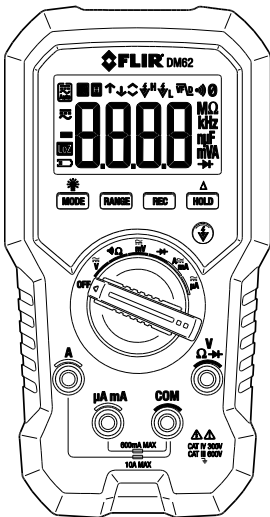

Table of Contents

1. ADVISORIES	4
1.1 Copyright	4
1.2 Quality Assurance	4
1.3 Documentation	4
1.4 Disposal of Electronic Waste	4
2. SAFETY	5
3. INTRODUCTION	7
4. METER AND DISPLAY DESCRIPTIONS	8
4.1 Front and Back Meter Descriptions	8
4.2 Rotary Function Selector	9
4.3 Control Buttons	9
4.4 Display Description	10
5. BASIC OPERATION AND FEATURES	11
5.1 Powering the Meter	11
5.2 Intelligent Auto Power OFF (APO)	11
5.3 LCD Backlight	11
5.4 Auto/Manual Range Mode	11
5.5 True RMS Response	11
5.6 Crest Factor	11
5.7 Out-of-range Warning (O.L)	11
5.8 Data Hold	12
5.9 Relative Zero Mode	12
5.10 VFD Mode (Low Pass Filter) Models DM64/DM66 only	12
5.11 MAX-MIN-AVG Record Mode	12
5.12 Test Lead Input Warning	12
5.13 Auto Voltage AC/DC Detection in 'Lo Z' mode (DM64/DM66 only)	12
6. MEASUREMENTS	13
6.1 AC/DC Voltage Measurements (VFD and Frequency on DM64/DM66)	13
6.2 Low Impedance (Lo Z) Auto-Voltage Measurements (DM64/66 only)	14
6.3 Line Frequency Measurements (DM64/DM66 only)	15
6.4 Resistance and Continuity Measurements	16
6.5 Capacitance (DM64/DM66) and Diode Measurements	17
6.6 AC/DC mV and Temperature (DM64/DM66) Measurements	19

6.7 μ A, mA, A Current Measurements with Frequency (DM64/DM66)	21
6.8 NCV (Non-Contact Voltage) Detection	22
7. MAINTENANCE	23
7.1 Cleaning and Storage	23
7.2 Battery and Fuse Replacement	23
7.3 Disposal of Electronic Waste	23
8. SPECIFICATIONS	24
8.1 General specifications	24
8.2 Electrical Specifications	25
9. TECHNICAL SUPPORT	29
10. THREE-YEAR LIMITED WARRANTY	30

1. Advisories

1.1 Copyright

© 2018, FLIR Systems, Inc. All rights reserved worldwide. No parts of the software including source code may be reproduced, transmitted, transcribed or translated into any language or computer language in any form or by any means, electronic, magnetic, optical, manual or otherwise, without the prior written permission of FLIR Systems. The documentation must not, in whole or part, be copied, photocopied, reproduced, translated or transmitted to any electronic medium or machine readable form without prior consent, in writing, from FLIR Systems.

Names and marks appearing on the products herein are either registered trademarks or trademarks of FLIR Systems and/or its subsidiaries. All other trademarks, trade names or company names referenced herein are used for identification only and are the property of their respective owners.

1.2 Quality Assurance

The Quality Management System under which these products are developed and manufactured has been certified in accordance with the ISO 9001 standard.

FLIR Systems is committed to a policy of continuous development; therefore, we reserve the right to make changes and improvements on any of the products without prior notice.

1.3 Documentation

To access the latest manuals and notifications, go to the Download tab at:

<http://support.flir.com>. It only takes a few minutes to register online. In the download area you will also find the latest releases of manuals for our other products, as well as manuals for our historical and obsolete products.

1.4 Disposal of Electronic Waste



As with most electronic products, this equipment must be disposed of in an environmentally friendly way, and in accordance with existing regulations for electronic waste.

Please contact your FLIR Systems representative for more details.

2. Safety

Safety Notes

This manual contains information and warnings that must be followed for operating the meter safely and maintaining the meter in a safe operating condition. If the meter is used in a manner not specified by the manufacturer, the protection provided by the meter may be impaired.

Terms in this manual

WARNING Identifies conditions and actions that could result in serious injury or even death to the user.

CAUTION Identifies conditions and actions that could cause damage or malfunction in the instrument.

WARNING

To reduce the risk of fire or electric shock, do not expose this product to rain or moisture. The meter is intended only for indoor use.

Keep your hands/fingers behind the hand/finger barriers (of the meter and the test probe assembly, where applicable) that indicate the limits of safe access of the hand-held parts during measurements. Inspect lead wires, connectors, and probes for damaged insulation or exposed metal before using the meter. If any defects are found, replace them immediately. Only use the probe assembly provided with the meter or a UL Listed Probe Assembly to the same meter ratings or better.

IEC 61010-031 requires exposed conductive test probe tips to be $\leq 4\text{mm}$ for CAT III & CAT IV ratings. Refer to the category markings on your probe assemblies as well as on the add-on accessories (like detachable Caps or Alligator Clips), if any, for applicable rating changes.

Observe proper safety precautions when working with voltages above 33 Vrms, 46.7 Vpeak or 70 VDC. These voltage levels pose a potential shock hazard to the user. Before and after hazardous voltage measurements, check the voltage function on a known source such as line voltage to determine proper meter functioning.

CAUTION

Disconnect the test leads from the test points before changing functions.

International Electrical Symbols



Marking of Electrical and Electronic Equipment (EEE). Do not dispose of this product as unsorted municipal waste. Contact a qualified recycler



Caution! Refer to the explanation in this Manual



Caution! Possibility of electric shock



Earth (Ground)



Meter protected throughout by Double Insulation or Reinforced insulation



Fuse



Direct Current (DC)



Alternating Current (AC)



Three-phase Alternating Current

Measurement Categories

Measurement Category IV is applicable to test and measuring circuits connected at the source of the building's low-voltage MAINS installation. Examples are measurements on devices installed before the main fuse or circuit breaker in the building installation.

Measurement Category III is applicable to test and measuring circuits connected to the distribution part of the building's low-voltage MAINS installation. Examples are measurements on distribution boards (including secondary meters), circuit-breakers, wiring, including cables, bus-bars, junction boxes, switches, and socket-outlets in the fixed installation, and equipment for industrial use and some other equipment such as stationary motors with permanent connection to the fixed installation.

CENELEC DIRECTIVES

The instruments conform to CENELEC Low-voltage directive 2014/35/EC, Electromagnetic compatibility directive 2014/30/EU and RoHS directive 2011/65/EU.

3. Introduction

Thank you for selecting the FLIR DM6x Digital Multimeter. This meter can measure up to 600V and 10A AC/DC. This device is shipped fully tested and calibrated and, with proper use, will provide years of reliable service.

Features

- 6000 Count (3-5/6 digits) backlit LCD with 5 reading per second update rate
- Auto Power OFF
- Measures ACV, DCV, Resistance, Continuity, Capacitance*, Diode, DCA, ACA, Temperature*, line Frequency*, non-contact Voltage (NCV)
- True RMS responding
- Auto AC/DC detection for voltage measurements*
- Lo Z (low impedance) for ghost voltage protection*
- Auto ranging
- VFD feature (low pass filter for AC voltage measurements)*
- MIN-MAX-AVG Reading Memory
- Relative Zero mode
- Equipped with test leads, batteries, printed Quick Start (full User Manual available on FLIR website <http://support.flir.com>), and type K thermocouple*
- Optional accessories: Banana plug to type-K socket plug adaptor*, magnetic hanger, and carrying pouch

*Applies to models DM64 and DM66 only

4. Meter and Display Descriptions

4.1 Front and Back Meter Descriptions

1. Non-Contact Voltage Detector
2. LCD
3. Control buttons
4. Rotary Selector Switch
5. 'A' Current input terminal
6. 'uA, mA' Current input terminal
7. COM (negative -) input terminal
8. Positive (+) input terminal for all inputs except Current
9. Battery compartment lock and fuse access
10. Test Lead holders
11. Battery compartment and fuse access
12. Tilt stand

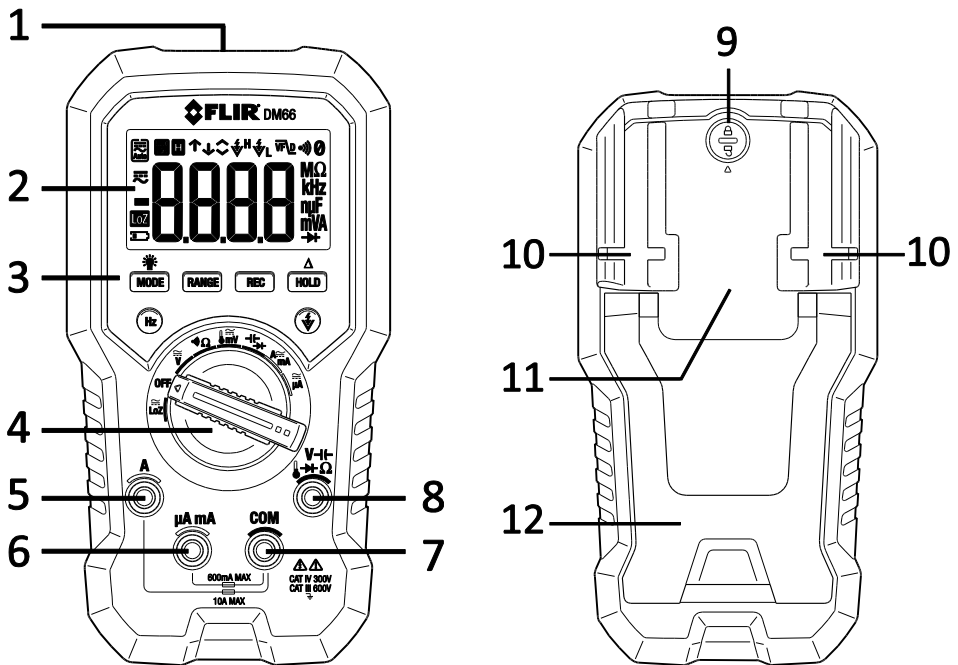

















Fig. 4-1 Front and Back Views (DM66)

4.2 Rotary Function Selector

	Lo Z (low impedance) mode with Auto ACV/DCV detection (DM64/DM6)
OFF	Meter power off
	AC/DC Voltage and VFD (low pass filter) modes (VFD available in models DM64/DM66 only)
	Resistance and Continuity measurements
	Temperature (DM64 and DM66 only) and AC/DC milli-volt measurements
	Capacitance (DM64 and DM66 only) and Diode measurements
	AC/DC Amp and milli-amp current measurements
	AC/DC micro-amp current measurements

4.3 Control Buttons

	Long press to switch LCD Backlight ON/OFF
	Mode select button. For rotary switch positions with more than one function, use this button to select the desired function
	Short press to select MANUAL mode and to change ranges, long press to return to AUTO. Also used to select sensitivity in NCV mode and trigger level for line frequency measurements (DM64/DM66)
	Short press to access MIN-MAX-AVG Record mode. Short press to step through MIN-MAX-AVG readings. Long press to exit
	Long press the Relative/Zero button to switch the mode ON/OFF. When switched on, the displayed reading is stored as reference/offset value
	Data Hold button. Short press to freeze/unfreeze displayed reading
	Frequency button (DM64/DM66). Short press to view frequency for AC measurements
	Short press the Non-Contact Voltage (NCV) button to switch ON/OFF. Use RANGE to select high (H) 24~1000V or low (L) 100~1000V sensitivity

4.4 Display Description

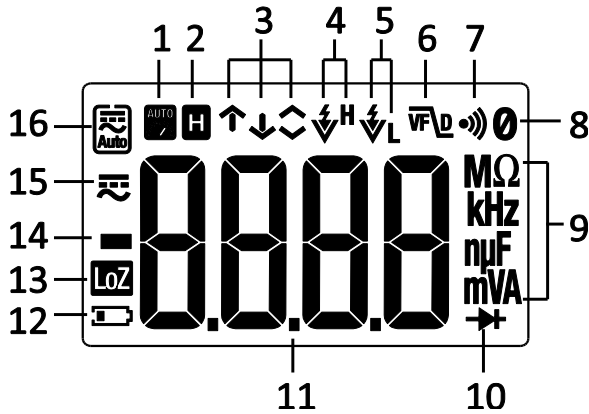

Fig. 4-2 LCD Display Icons

1. Automatic Range mode
2. Data Hold
3. Maximum, Minimum, and Average Reading Record modes
4. High Sensitivity NCV mode
5. Low Sensitivity NCV mode
6. VFD (low pass filtering) mode*
7. Continuity test
8. Relative/Zero function
9. Units of measure
10. Diode test
11. Main display digits
12. Battery status
13. Lo Z (low impedance) mode*
14. Minus symbol
15. AC and DC symbols
16. Automatic ACV/DCV detection in Lo Z mode*

*Models DM64/DM66 only

5. Basic Operation and Features

5.1 Powering the Meter

1. Set the function switch to any position to switch on the meter.
2. If the battery status indicator appears low or if the meter does not power on, replace the two (2) 'AAA' batteries. See [Section 12.2, Battery Replacement](#).

5.2 Intelligent Auto Power OFF (APO)

The meter will intelligently avoid entering the APO mode under normal measurement conditions. The APO feature turns the meter off automatically, in order to extend battery life, after approximately 32 minutes if none of the conditions below are met:

- 1) Rotary switch or push button operation
- 2) Significant measurement value (reading above 8.5% of the range)
- 3) Non-OL readings for Resistance, Continuity or Diode function
- 4) Non-zero readings for Hz function
- 5) Electric field signal present for EF NCV function

To wake the meter from APO, short press the **MODE** button, or turn the rotary switch OFF and then back on. Always turn the rotary switch to the OFF position when the meter is not in use.

5.3 LCD Backlight

Long press the  backlight button to toggle the LCD backlight ON and OFF. The backlight will automatically switch OFF after 10 minutes to conserve battery energy.

5.4 Auto/Manual Range Mode

For most auto-ranging functions, short press the **RANGE** button to select manual-ranging override. The meter will remain in the range it was in and the auto range display icon will switch off. Short press the button again to select the next range. Long press the button to resume auto-ranging. **Note:** Manual-ranging is not available for Auto-V, Capacitance & Hz functions.

5.5 True RMS Response

True RMS (Root Mean Square) allows the meter to respond accurately to the effective RMS value, regardless of the waveform shape (square, saw-tooth, triangle, pulse, spike, as well as distorted waveforms with the presence of harmonics).

5.6 Crest Factor

Crest Factor is the ratio of the Crest (instantaneous peak) value to the True RMS value. A pure sine wave has a Crest Factor of 1.414. A badly distorted sinusoidal waveform normally has a much higher Crest Factor.

5.7 Out-of-range Warning (O.L)

If the input is over/under the full-scale range in Manual range mode, or if the signal has exceeded the maximum/minimum input in Auto range mode, 'O.L' is displayed.

5.8 Data Hold

In Data Hold mode, the displayed reading is held. To enter/exit Data Hold mode, short press the **HOLD** button. In Hold mode, the **H** indicator is displayed.

5.9 Relative Zero Mode

Relative Zero allows the user to offset measurements by the amount determined by a stored reference value. Almost any displayed reading can be set as the relative reference value including MAX/MIN/AVG readings. Long press the **Δ** button to toggle Relative Zero mode ON and OFF.

When switched ON, the meter stores the displayed reading as the offset/reference value, the zero (0) symbol appears on the upper right, and the meter will display the measurement value minus the stored reference.

5.10 VFD Mode (Low Pass Filter) Models DM64/DM66 only

The VFD (variable-frequency drive) utility eliminates high-frequency noise from AC voltage measurements. This is accomplished using a low-pass filter. To activate, short press the **MODE** button until the VFD symbol appears.

5.11 MAX-MIN-AVG Record Mode

Short press **REC** to activate the recording mode, three arrow icons (**↑** [MAX], **↓** [MIN], and **↻** [AVG]) will appear indicating that the meter is now recording. Short press the **REC** button to step through the MAX-MIN-AVG readings. The meter beeps when new MAX or MIN readings are detected. Long press **REC** to exit the recording mode. Auto-ranging is active and Auto-Power-Off is disabled in this mode.

5.12 Test Lead Input Warning

The meter beeps (at a fast rate) as well as displays “**InEr**” to warn the user that an improper connection to the **μA**, **mA**, or **A** input jack is being made when another function, especially a voltage function, is selected.

5.13 Auto Voltage AC/DC Detection in ‘Lo Z’ mode (DM64/DM66 only)

Auto Voltage ‘Lo Z’ mode automatically selects DCV or ACV, based on input levels detected through the test leads. This mode uses a ‘Lo Z’ low ramp-up impedance (approx. 2.1kΩ for low voltages) to drain ghost voltages. Refer to Section 6.2 *Low Impedance Auto-Voltage Measurements* for complete details.

6. Measurements

Caution: Before and after hazardous voltage measurements, test the voltage function on a known source such as line voltage to determine proper meter functioning.

Caution: Before operating the device, you must read, understand, and follow all instructions, dangers, warnings, cautions, and notes.

Caution: When the meter is not in use, the function switch should be set to the OFF position.

Caution: When connecting the probe leads to the device under test, connect the COM (negative) lead before connecting the positive lead. When removing the probe leads, remove the positive lead before removing the COM (negative) lead.

6.1 AC/DC Voltage Measurements (VFD and Frequency on DM64/DM66)

Move the rotary switch to the \tilde{V} position and short press the **MODE** button to step through the following modes: DCV, ACV, and ACV with VFD*. The last selection will be saved as the power-up default. For AC, short press the **Hz** button to view the frequency* and press again to return to the voltage measurement (refer to Section 6-3 for more on Frequency measurement features). Refer to Fig. 6-1 for function switch position, test lead connection, push-button operation, and display example.

*VFD and Frequency available on models DM64/DM66 only

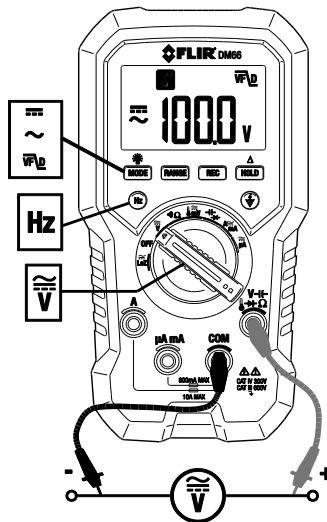

Figure 6-1 – ACV, DCV, and VFD application diagram

Notes: VFD-ACV and the associated Hz measurement are equipped with a digital low-pass filter, and are capable of handling VFD (Variable Frequency Drives) signals for fundamental V & Hz readings. It also improves ACV and Hz reading stability when being used in noisy electrical environments.

6.2 Low Impedance (Lo Z) Auto-Voltage Measurements (DM64/66 only)

Auto Voltage Lo Z mode automatically selects DCV or ACV, based on input levels detected through the test leads. This mode uses a 'Lo Z' low ramp-up impedance (approx. 2.1k Ω for low voltages) to drain ghost voltages*. Refer to Fig. 6-2 for function switch position, test lead connection, and display example.

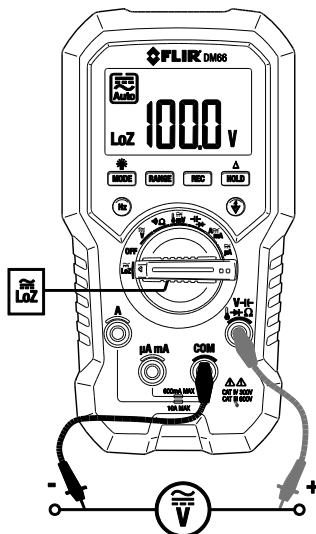

Figure 6-2 – LoZ application diagram

- With no input, the meter displays “- - -” when it is ready for testing.
- When a signal above the voltage threshold of 8.0V DC or 5.5V AC (up to the rated 600V) is present, the meter displays the voltage value in DC or AC, whichever is larger in peak magnitude. Attempting to measure ‘Lo Z’ voltages below these limits will result in the same readings as for the normal voltage measurement mode.

Notes:

*Ghost-voltages are unwanted stray signals, coupled from adjacent live signals, which can confuse common Multimeter voltage measurements. This feature is helpful when distinguishing between hot and open wires (to ground) in electrical installations, for example. Only **HOLD**, **EF (NCV)** & **Backlight** push-button features are available in Auto Voltage mode.

WARNING:

Lo Z Auto Voltage mode input impedance increases abruptly from the initial 2.1k Ω to a few hundred k Ω 's on high voltage hard signals. “Lo Z” appears on the LCD as a reminder. Peak initial load current, while probing 1000VAC for example, can be as high as 673mA ($1000V \times 1.414 / 2.1k\Omega$), decreasing abruptly to approx. 2.4mA ($1000V \times 1.414 / 580k\Omega$) within a fraction of a second. Do not use this feature on circuits that could be damaged by such low input impedance. Instead, use the high input impedance voltage modes to minimize loading on such circuits (rotary switch set to the \overline{V} position).

6.3 Line Frequency Measurements (DM64/DM66 only)

Short press the **Hz** button to toggle the frequency function ON and OFF. Refer to Fig. 6-3 for function switch position, test lead connection, push-button operation, and display example. A voltage application is shown in Fig. 6-3, but line frequency can also be viewed in AC Current applications; however, the input sensitivity adjustment, as detailed below, applies to AC Voltage applications only.

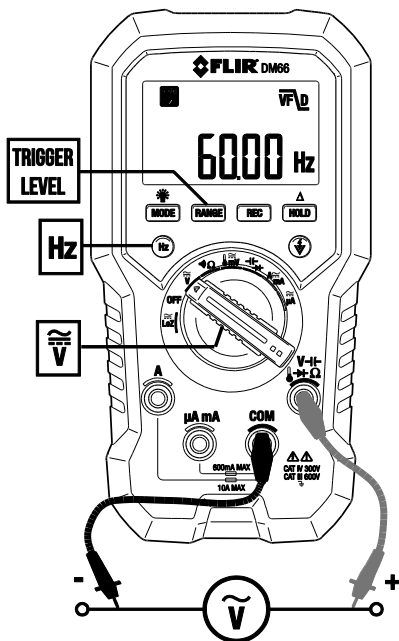

Figure 6-3 – Line Frequency Measurements (Hz) for ACV/VFD

Note on Input Sensitivity for voltage applications:

Input sensitivity varies automatically with the range selected. The 6V range has the highest sensitivity and the 1000V range has the lowest. In the DCV, ACV or VFD-ACV voltage functions, the trigger voltage will be displayed immediately before starting the Hz measurement. While displayed, short press the **RANGE** button to manually select another trigger voltage range (voltage modes only). First measure the signal voltage (or current) level and then activate the Hz function in that range to find the optimum **trigger level**. If the Hz reading becomes unstable, select a lower sensitivity to avoid electrical noise. If the reading shows zero, select a higher sensitivity.

6.4 Resistance and Continuity Measurements

Warning: Do not perform resistance or continuity tests before removing power from capacitors and other devices under test during a measurement. Injury to persons can occur.

Short press the **MODE** button to toggle Resistance and Continuity functions. The last selection will be saved as the power-up default. Refer to the Fig. 6-4 for function switch position, test lead connection, push-button operation, and display examples.

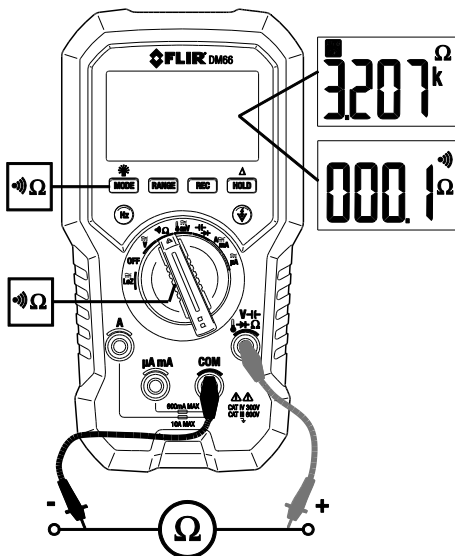

Figure 6-4 – Resistance and Continuity Measurements

))) For convenience, the Continuity function offers a continuous beep tone together with a flashing LCD backlight indicating a complete wire. This audio-visual indication is especially handy in noisy work environments. If the resistance is $< 30\Omega$ the meter beeps. If the resistance is $> 480\Omega$ the meter will not beep. If the resistance is $> 30\Omega$ but $< 480\Omega$ the beeping will stop at an unspecified point.

CAUTION

Be sure to remove power from any circuit or device before measuring resistance and continuity. Measuring resistance and continuity on a live circuit will produce false results and may damage the instrument.

6.5 Capacitance (DM64/DM66) and Diode Measurements

Warning: Do not perform capacitance or diode tests before removing power to the devices under test. Injury to persons can occur.

Short press the **MODE** button to toggle the Capacitance and Diode functions. The last selection will be saved as the power-up default. Refer to the Fig. 6-5 for function switch position, test lead connection, push-button operation, and display example for Capacitance testing. Refer to Fig 6-6 for diode testing.

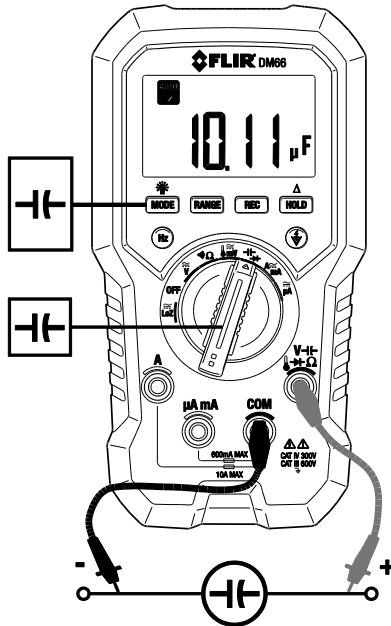

Figure 6-5 – Capacitance Testing

CAUTION

Discharge capacitors before making any measurements. Large value capacitors should be discharged through an appropriate resistance load. Large value capacitors will require ample time before a stable reading is displayed.

In the **Diode** mode, the normal forward voltage drop (forward biased) for a good silicon diode is between 0.400V to 0.900V (Fig 6-6, left). A reading higher than that indicates a leaky diode (defective). A zero reading indicates a shorted diode (defective). An OL display indicates an open diode (defective). Reverse the test lead connection (reverse biased) across the diode (Fig 6-6, right). The digital display shows OL if the diode is good. Any other readings indicate that the diode is resistive or shorted (defective).

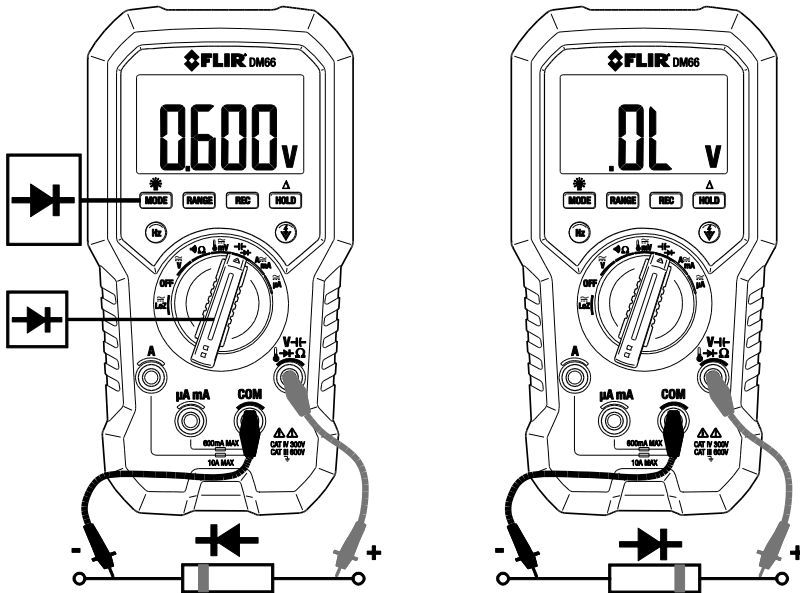

Figure 6-6 – Diode testing (forward bias on left; reverse bias on right)

6.6 AC/DC mV and Temperature (DM64/DM66) Measurements

Short press the **MODE** button to step through mV AC/DC and Temperature °C/°F functions (temperature available only on DM64/DM66). The last selection will be saved as the power-up default. Refer to the Fig. 6-7 for function switch position, test lead connection, push-button operation, and display example for mV measurements. Short press the **Hz** button to switch the Frequency measurement mode on/off in AC mV mode. Refer to Fig 6-8 for Temperature measurements.

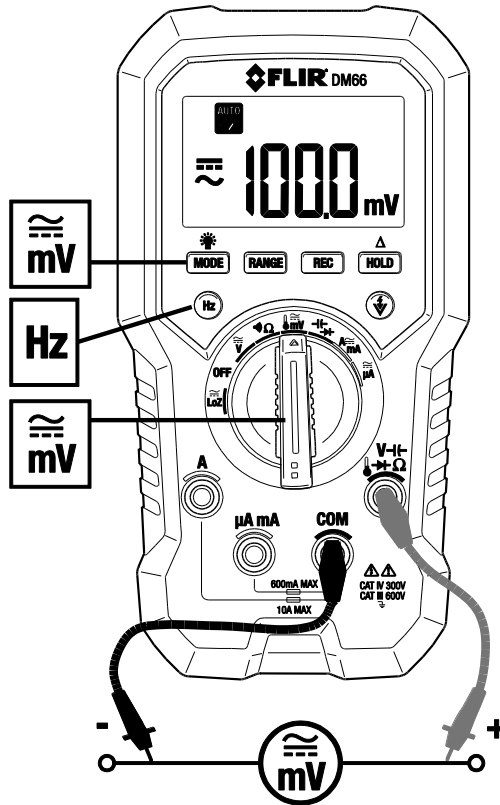

Figure 6-7 – AC/DC mV measurements

Insert the banana plug type-K temperature bead probe observing correct polarity. You can also use a plug adaptor (optional) with banana plug to type-K socket to adapt other standard type-K mini plug temperature probes (see the drawing on the right of Fig 6-8, for adaptor illustration).

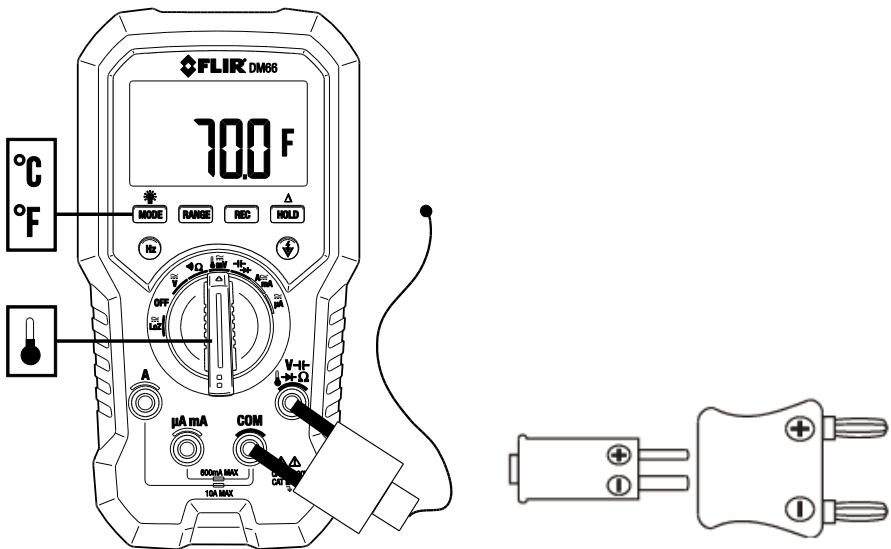
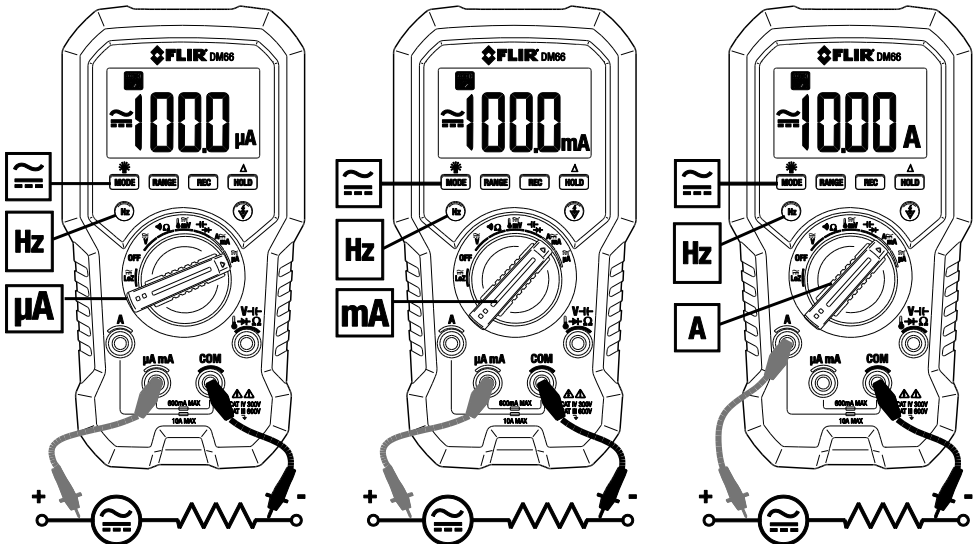

Figure 6-8 – Temperature measurements (optional adaptor shown on right)

6.7 μA , mA, A Current Measurements with Frequency (DM64/DM66)

⚠ WARNING Do not measure current on a circuit when the voltage increases to more than 600V. This can cause damage to the instrument and can cause injury to persons.

Short press the **MODE** button to toggle DC and AC modes. The last selection will be saved as the power-up default. Refer to the Fig. 6-9 for function switch position, test lead connection, push-button operation, and display examples. Short press the **Hz** button to view the frequency measurement in AC current modes. Frequency is available only on the DM64/DM66 models.



*Figure 6-9 – Current measurements
(μA on left, mA in the center, and A, on right)*

6.8 NCV (Non-Contact Voltage) Detection

Short press the  button to switch ON/OFF the non-contact voltage (NCV) detector. The meter displays **H** or **L** (for **H**igh 24~1000V or **L**ow 100~1000V sensitivity) when it is ready. Short press the **RANGE** button to change the sensitivity. Place the top left of the meter near a conductor to test. The detected voltage strength is indicated as a series of display dashes and a variable beeper tone. Refer to the Fig. 6-10 for function switch position, push-button operation, and display example.

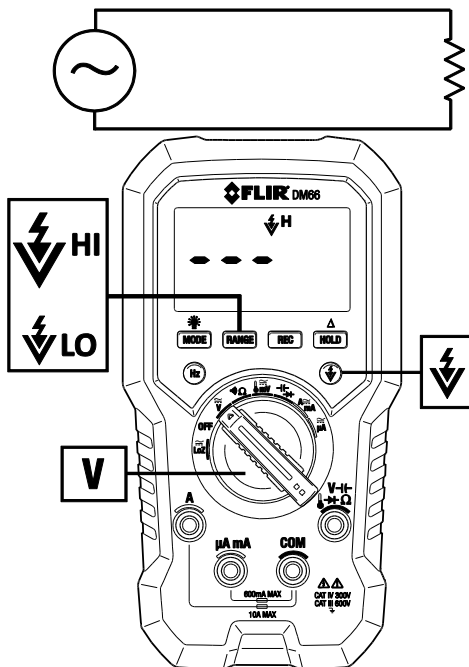

Figure 6-10 – Non-Contact Voltage Detection

An antenna is located along the top-left end of the meter which detects the electric fields that surround energized, live conductors. It is ideal for tracing live wiring connections, locating wiring breakages and distinguishing between live and earth connections.

7. Maintenance

7.1 Cleaning and Storage

Wipe the housing with a damp cloth as needed. Please do not use abrasives or solvents to clean the meter. If the meter is not to be used for an extended period, remove the batteries and store them separately.

7.2 Battery and Fuse Replacement

WARNING: To avoid electrical shock, disconnect the meter from any connected circuits, remove the test leads from the meter terminals, and set the function switch to the OFF position before attempting to replace the batteries or fuses.

1. To replace the batteries, unlock the battery compartment by rotating the lock with a screwdriver or other tool (the lock is item 1 in the accompanying diagram).
2. Remove the battery compartment cover.
3. Replace the two (2) 1.5V 'AAA' batteries, observing correct polarity.
4. Replace the battery cover and re-lock it before operating the meter.
5. To replace the fuses, lift the tilt stand and locate the two screw holes (item 2 in the diagram).
6. The screws are protected by rubber grommets which must be removed before the screws can be accessed.
7. Remove the two screws and remove one additional screw located just behind the battery compartment lock to access the fuse area.
8. Replace **Fuse F1** for $\mu\text{A}/\text{mA}$ current input with a 0.4A/600V DC/AC, IR 30kA F fuse or better; Dimension: 6 x 32 mm
9. Replace **Fuse F2** for 'A' current input with a 11A/600V DC/AC, IR 20kA F fuse or better; Dimension: 10 x 38mm
10. Secure the meter before operating.

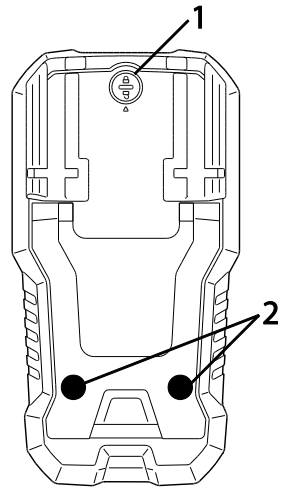

7.3 Disposal of Electronic Waste

As with most electronic products, this equipment must be disposed of in an environmentally friendly way, and in accordance with existing regulations for electronic waste. Please contact your FLIR Systems representative for more details.

8. Specifications

8.1 General specifications

Display: 3-5/6 digits 6,000 counts

Update Rate: 5 per second nominal

Operating Temperature: 14°F ~ 122°F (-10°C ~ 50°C)

Relative Humidity: Maximum relative humidity 80% for temperature up to 87.8°F (31°C) decreasing linearly to 50% relative humidity at 122°F (50°C)

Altitude: Operating below 6562'(2000m)

Storage Temperature: -4°F ~ 140°F (-20°C ~ 60°C), < 80% R.H. (with battery removed)

Temperature Coefficient: Nominal 0.15 x (specified accuracy)/ °C @ (14°F ~ 64.6°F [-10°C ~ 18°C]) or 82.4°F ~ 122°F [28°C ~ 50°C]), or as otherwise specified

Sensing: True RMS response

Ingress Protection: IP40

Drop-proof: to 6.5' (2m)

Pollution Degree: 2

Safety: Certified per IEC/UL/EN61010-1 Ed. 3.0, IEC/UL/EN61010-2-030 Ed. 1.0, IEC/UL/EN61010-2-033 Ed. 1.0, IEC/UL/EN61010-031 Ed. 1.1 and the corresponding CAN/CSA-C22.2 regulations to Measurement Categories:

CAT III 600V and CAT IV 300V AC & DC

Transient Protection: 6.0kV (1.2/50µs surge)

E.M.C.: Meets EN61326-1:2013

In an RF field of 3V/m:

Temperature function is not specified

Ohm function: Total Accuracy = Specified Accuracy + 15 digits

Other functions: Total Accuracy = Specified Accuracy

Performance above 3V/m is not specified

Overload Protection:

µA & mA: 0.4A/600V DC/AC rms, IR 30kA, F fuse or better

A: 11A/1000V DC/AC rms, IR 20kA, F fuse or better

V & Auto Voltage modes: 600V DC/AC rms

mV, Ohm & others: 600V DC/AC rms

Low Battery warning: Below approx. 2.5V

Power Supply: 1.5V AAA Size battery x 2

Power Consumption (typical): 3.2mA

APO Consumption (typical): 10 μ A

APO Timing: Powers off after 30 minutes of inactivity

Dimension: 6.3 x 3.1 x 2.0" (161 x 80 x 50mm) L x W x H

Weight: Approx. 11.8 oz. (334 g)

Special Features: Auto Voltage (Lo Z) (DM64/DM66); VFD; Audio-visual Continuity; Auto-ranging MAX/MIN/AVG Record; Backlit LCD; Auto-ranging Relative Zero mode; Display Hold; EF-Detection (NCV); Test lead warning on μ A-mA/A terminals

Accessories: Test lead pair; 2 x 1.5V 'AAA' batteries installed; Quick Start manual; Banana plug type-K thermocouple (DM64/DM66 only)

Optional Purchase Accessories: Banana plug to type-K socket plug adaptor (DM64/DM66 only); Magnetic hanger; Soft carrying pouch

8.2 Electrical Specifications

Accuracy is \pm (% reading + number of digits (dgt)) at 73.4 °F \pm 9 °F (23 °C \pm 5 °C), <80% RH.

ACV & ACA accuracies are specified from 1 % to 100 % of range or as otherwise specified. Maximum Crest Factor <2:1 at full scale & <4:1 at half scale, and with frequency components fall within the meter specified frequency bandwidth for non-sinusoidal waveforms

AC Voltage

RANGE	Accuracy
50Hz ~ 60Hz	
6.000V ¹⁾ , 60.00V, 600.0V	0.7% + 3d
45Hz ~ 440Hz	
6.000V ¹⁾ , 60.00V, 600.0V	2.0% + 3d

Input Impedance: 10M Ω , 54pF nominal

¹⁾ <5d non-zero residue may appear when backlight is on, which will not affect the specified measuring range and accuracy

ACmV

RANGE	Accuracy
10Hz ~ 500Hz	
60.00mV ^{1) 2)} , 600.0mV ³⁾	1.0% + 3d
500Hz ~ 800Hz	
60.00mV ^{1) 2)} , 600.0mV ³⁾	2.0% + 3d

Input Impedance: 10M Ω , 54pF nominal

¹⁾ <5d non-zero residue may appear when backlight is on, which will not affect the specified measuring range and accuracy

²⁾ Signal peak absolute values, including DC bias, less than 130mV_{peak}

³⁾ Signal peak absolute values, including DC bias, less than 1300mV_{peak}

VFD_ACV (with Low Pass Filter) DM64/DM66 only

RANGE	Accuracy ¹⁾
10Hz ~ 100Hz (fundamental)	
600.0V	1.0% + 3d
100Hz ~ 400Hz (fundamental)	
600.0V	10% + 3d ²⁾

¹⁾ Not specified for fundamental frequency > 400Hz

²⁾ Accuracy linearly decreases from 1% + 3d @100Hz to 10% + 3d @400Hz

Auto Voltage ACV (DM64/DM66)

RANGE	Accuracy ¹⁾
45Hz ~ 440Hz	
600.0V	2.0% + 3d

¹⁾ Not specified at <1VAC

Threshold: > 1VAC nominal

Approximate input impedance (//164pF) for reference:

At direct input ≤50Vac (typical) from quiescence:

>8MΩ @ < 5.6Vac

22kΩ @ 7Vac

12kΩ @ 8Vac

2.6kΩ @ 50Vac

At direct input >>50V (typical) from quiescence:

Initial impedance is approximately 2.1kΩ. Impedance increases abruptly within a fraction of a second as display voltage (hard signal) is much higher than 50V (typical).

Final impedances vs display voltages typically are:

12kΩ @100V

100kΩ @300V

240kΩ @600V

DC Voltage

RANGE	Accuracy
60.00mV, 600.0mV, 6.000V	0.3% + 2d
60.00V	0.4% + 2d
600.0V	0.2% + 2d

Input Impedance: 10MΩ, 54pF nominal

Auto Voltage DCV (DM64/DM66)

RANGE	Accuracy ¹⁾
600.0V	2.0% + 3d

¹⁾ Not specified at <1VDC

Threshold: > +1.0VDC or < -1.0VDC nominal

Approximate input impedance (//164pF) for reference:

At direct input ≤50Vdc (typical) from quiescence:

>8MΩ @ < 8Vdc (Protection clamping threshold)

25kΩ @ 9Vdc

13kΩ @ 10Vdc

2.6kΩ @ 50Vdc

At direct input >>50V (typical) from quiescence:

Initial impedance is approximately 2.1kΩ. Impedance increases abruptly within a fraction of a second as display voltage (hard signal) is much higher than 50V (typical).

Actual impedances vs display voltages typically are:

12kΩ @100V

100kΩ @300V

240kΩ @600V

Resistance (Ohms)

RANGE ¹⁾	Accuracy
600.0Ω, 6.000kΩ	0.3% + 3d
60.00kΩ, 600.0kΩ	0.5% + 3d
6.000MΩ ²⁾ , 60.00MΩ ³⁾	0.9% + 2d ⁴⁾

¹⁾ Open Circuit Voltage: 1.6VDC typical

²⁾ Constant Test Current: 0.2μA Typical

³⁾ Constant Test Current: 0.02μA Typical

⁴⁾ 5%+20d @ >30MΩ

Continuity Tester

Continuity Threshold: Between 30Ω and 480Ω

Continuity ON Response Time: <15ms

Audible Indication: Beeper sound

Visible Indication: LCD Backlight

Capacitance (DM64/DM66)

RANGE	Accuracy
20.00nF, 200.0nF	1.5% + 8d
2000nF, 20.00μF, 200.0μF, 2000μF	1.5% + 2d
10.00mF	4.5% + 10d

Accuracies with film capacitor or better

Diode Tester

RANGE	Accuracy
3.000V	0.9% + 2d

Test Current: 0.3mA typical

Open Circuit Voltage: < 3.2VDC typical

DC Current

RANGE	Accuracy	Burden Voltage
600.0µA, 6000µA	1.0% + 3d	0.1mV/µA
60.00mA, 600.0mA	0.7% + 3d	1.9mV/mA
6.000A, 10.00A ¹⁾		0.04V/A

¹⁾10A continuous, >10A to 20A for 30 seconds max with 5 minutes cool down interval

AC Current

RANGE	Accuracy	Burden Voltage
50Hz ~ 400Hz		
600.0µA, 6000µA	1.5% + 3d	0.1mV/µA
60.00mA, 600.0mA	1.0% + 3d	1.9mV/mA
6.000A ¹⁾ , 10.00A ²⁾		0.04V/A

¹⁾ <5d non-zero residue may appear when backlight is on, which will not affect the specified measuring range and accuracy

²⁾10A continuous, >10A to 20A for 30 seconds max with 5 minutes cool down interval

Temperature (DM64/DM66)

RANGE	Accuracy ^{1) 2)}
-40.0 °C ~ 99.9°C	1% + 1 °C
100 °C ~ 400°C	
-40.0 °F ~ 99.9 °F	1% + 2 °F
100 °F ~ 752 °F	

¹⁾ Accuracies assume meter interior and the ambient air have reached the same temperature for a correct junction voltage compensation. Allow enough settling time for a significant change of ambient temperature. It can take up to an hour for changes > 5°C (>9°F).

²⁾ Type-K thermocouple range & accuracy not included

Line Frequency (DM64/DM66)

Function	Sensitivity (Sine RMS)	Range
60mV, 600mV	50mV	10.00Hz ~ 50.00kHz
6V	5V	
60V	10V	
600V	50V	10.00Hz ~ 1.00kHz
VFD 600V	50V	
600μA, 6000μA	500μA	10.00Hz ~ 5.00kHz
60mA, 600mA	50mA	
6A, 10A	8A	50.00Hz ~ 1.00kHz

Accuracy: 0.03% + 2d

NCV Non-Contact Voltage Detection

Indication: Display dashes and audible beep tones proportional to a conductor's field strength.

Sensitivity: 'H' display for High sensitivity (24~1000V) and 'L' display for Low sensitivity (100~1000V), use the RANGE button to change the sensitivity.

Detection Frequency: 50/60Hz

Detection Antenna: Top-left of the meter

9. Technical Support

Main Website	http://www.flir.com/test
Technical Support Website	http://support.flir.com
Technical support Email	TMSupport@flir.com
Service/Repair Support Email	Repair@flir.com
Support Telephone number	+1 855-499-3662 option 3 (toll-free)

10. Three-Year Limited Warranty

Congratulations! You (the “Purchaser”) are now the owner of a world-class FLIR Test and Measurement product. A qualifying FLIR Test and Measurement product (the “Product”) purchased either directly from FLIR Commercial Systems Inc. and affiliates (FLIR) or from an authorized FLIR distributor that Purchaser registers on-line with FLIR is eligible for coverage under FLIR’s 3-Year Limited Warranty subject to the terms and conditions in this document. This warranty only applies to purchases of Qualifying Products (see below) purchased after April 2013 and only to the original Purchaser of the Product.

PLEASE READ THIS DOCUMENT CAREFULLY; IT CONTAINS IMPORTANT INFORMATION ABOUT THE PRODUCTS THAT QUALIFY FOR COVERAGE UNDER THE 3-YEAR LIMITED WARRANTY, PURCHASER’S OBLIGATIONS, HOW TO ACTIVATE THE WARRANTY, WARRANTY COVERAGE, AND OTHER IMPORTANT TERMS, CONDITIONS, EXCLUSIONS AND DISCLAIMERS.

1. PRODUCT REGISTRATION. To qualify for FLIR’s 3-Year Limited Warranty, the Purchaser must fully register the Product directly with FLIR on-line at www.flir.com WITHIN Sixty (60) DAYS of the date the Product was purchased by the first retail customer (the “Purchase Date”). PRODUCTS THAT ARE NOT REGISTERED ON-LINE WITHIN Sixty (60) DAYS OF THE PURCHASE DATE OR PRODUCTS WHICH DO NOT QUALIFY FOR THE 3-YEAR WARRANTY WILL HAVE A LIMITED ONE YEAR WARRANTY FROM THE DATE OF PURCHASE.

2. QUALIFYING PRODUCTS. Upon registration, a list of Test and Measurement Products that qualify for coverage under FLIR’s 3-Year Limited Warranty can be found at www.flir.com/testwarranty

3. THE WARRANTY PERIOD. The Product is warranted for a period of three (3) Years from the Purchase Date (the “Warranty Period”).

Any Product that is repaired or replaced under warranty is covered under this 3-Year Limited Warranty for one hundred eighty days (180) days from the date of return shipment by FLIR or for the remaining duration of the applicable Warranty Period, whichever is longer.

4. LIMITED WARRANTY. In accordance with the terms and conditions of this 3-Year Limited Warranty, and except as excluded or disclaimed in this document, FLIR warrants, from the Purchase Date, that all fully registered Products will conform to FLIR’s published Product specifications and be free from defects in materials and workmanship during the applicable Warranty Period. PURCHASER’S SOLE AND EXCLUSIVE REMEDY UNDER THIS WARRANTY, AT FLIR’S SOLE DISCRETION, IS THE REPAIR OR REPLACEMENT OF DEFECTIVE PRODUCTS IN A MANNER, AND BY A SERVICE CENTER, AUTHORIZED BY FLIR. IF THIS REMEDY IS ADJUDICATED TO BE INSUFFICIENT, FLIR SHALL REFUND PURCHASER’S PAID PURCHASE PRICE AND HAVE NO OTHER OBLIGATION OR LIABILITY TO BUYER WHATSOEVER.

5. WARRANTY EXCLUSIONS AND DISCLAIMERS. FLIR MAKES NO OTHER WARRANTY OF ANY KIND WITH RESPECT TO THE PRODUCTS. ALL OTHER WARRANTIES, EXPRESS OR IMPLIED, INCLUDING BUT NOT LIMITED TO IMPLIED WARRANTIES OF MERCHANTABILITY, FITNESS FOR A PARTICULAR PURPOSE (EVEN IF PURCHASER HAS NOTIFIED FLIR OF ITS INTENDED USE FOR THE PRODUCTS), AND NON-INFRINGEMENT ARE EXPRESSLY EXCLUDED FROM THIS AGREEMENT. THIS WARRANTY EXPRESSLY EXCLUDES ROUTINE PRODUCT MAINTENANCE, AND SOFTWARE UPDATES, AND REPLACEMENT OF FUSES OR DISPOSABLE BATTERIES. FLIR FURTHER EXPRESSLY

DISCLAIMS ANY WARRANTY COVERAGE WHERE THE ALLEGED NONCONFORMITY IS DUE TO NORMAL WEAR AND TEAR, ALTERATION, MODIFICATION, REPAIR, ATTEMPTED REPAIR, IMPROPER USE, IMPROPER MAINTENANCE, NEGLIGENCE, ABUSE, IMPROPER STORAGE, FAILURE TO FOLLOW ANY PRODUCT INSTRUCTIONS, DAMAGE (WHETHER CAUSED BY ACCIDENT OR OTHERWISE), OR ANY OTHER IMPROPER CARE OR HANDING OF THE PRODUCTS CAUSED BY ANYONE OTHER THAN FLIR OR FLIR'S EXPRESSLY AUTHORIZED DESIGNEE.

THIS DOCUMENT CONTAINS THE ENTIRE WARRANTY AGREEMENT BETWEEN PURCHASER AND FLIR AND SUPERSEDES ALL PRIOR WARRANTY NEGOTIATIONS, AGREEMENTS, PROMISES AND UNDERSTANDINGS BETWEEN PURCHASER AND FLIR. THIS WARRANTY MAY NOT BE ALTERED WITHOUT THE EXPRESS WRITTEN CONSENT OF FLIR.

6. WARRANTY RETURN, REPAIR AND REPLACEMENT. To be eligible for warranty repair or replacement, Purchaser must notify FLIR within thirty (30) days of discovering of any apparent defect in materials or workmanship. Before Purchaser may return a Product for warranty service or repair, Purchaser must first obtain a returned material authorization (RMA) number from FLIR. To obtain the RMA number Owner must provide an original proof of purchase. For additional information, to notify FLIR of an apparent defect in materials or workmanship, or to request an RMA number, visit www.flir.com. Purchaser is solely responsible for complying with all RMA instructions provided by FLIR including but not limited to adequately packaging the Product for shipment to FLIR and for all packaging and shipping costs. FLIR will pay for returning to Purchaser any Product that FLIR repairs or replaces under warranty.

FLIR reserves the right to determine, in its sole discretion, whether a returned Product is covered under warranty. If FLIR determines that any returned Product is not covered under warranty or is otherwise excluded from warranty coverage, FLIR may charge Purchaser a reasonable handling fee and return the Product to Purchaser, at Purchaser's expense, or offer Purchaser the option of handling the Product as a non-warranty return. FLIR shall not be responsible for any data, images or other information that may be stored on the returned Product which was not included in the Product at the time of purchase. It is Purchaser's responsibility to save any and all data prior to returning the Product for warranty service.

7. NON-WARRANTY RETURN. Purchase may request that FLIR evaluate and service or repair a Product not covered under warranty, which FLIR may agree to do in its sole discretion. Before Purchaser returns a Product for non-warranty evaluation and repair, Purchaser must contact FLIR by visiting www.flir.com to request an evaluation and obtain an RMA. Purchaser is solely responsible for complying with all RMA instructions provided by FLIR including but not limited to adequately packaging the Product for shipment to FLIR and for all packaging and shipping costs. Upon receipt of an authorized non-warranty return, FLIR will evaluate the Product and contact Purchaser regarding the feasibility of and the costs and fees associated with Purchaser's request. Purchaser shall be responsible for the reasonable cost of FLIR's evaluation, for the cost of any repairs or services authorized by Purchaser, and for the cost of repackaging and returning the Product to Purchaser.

Any non-warranty repair of a Product is warranted for one hundred eighty days (180) days from the date of return shipment by FLIR to be free from defects in materials and workmanship only, subject to all of the limitations, exclusions and disclaimers in this document.



Corporate Headquarters
FLIR Systems, Inc.
2770 SW Parkway Avenue
Wilsonville, OR 97070
USA
Telephone: +1 503-498-3547

Customer Support
Technical Support Website
Technical Support Email
Service and Repair Email
Customer Support Telephone

<http://support.flir.com>
TMSupport@flir.com
Repair@flir.com
+1 855-499-3662 option 3 (toll free)

Publication Identification No.:	DM6x-en-US
Release Version:	AA
Release Date:	January 2018
Language:	en-US